

EDSYN^{INC}®

951SX-230

LONER[®]

Temperature Controlled Soldering Station

- COMPLIES WITH MIL-S-45743E, MIL-STD-2000-1B, WS6536E AND ESD SPEC, DOD-STD-1686, DOD-HDBK-263

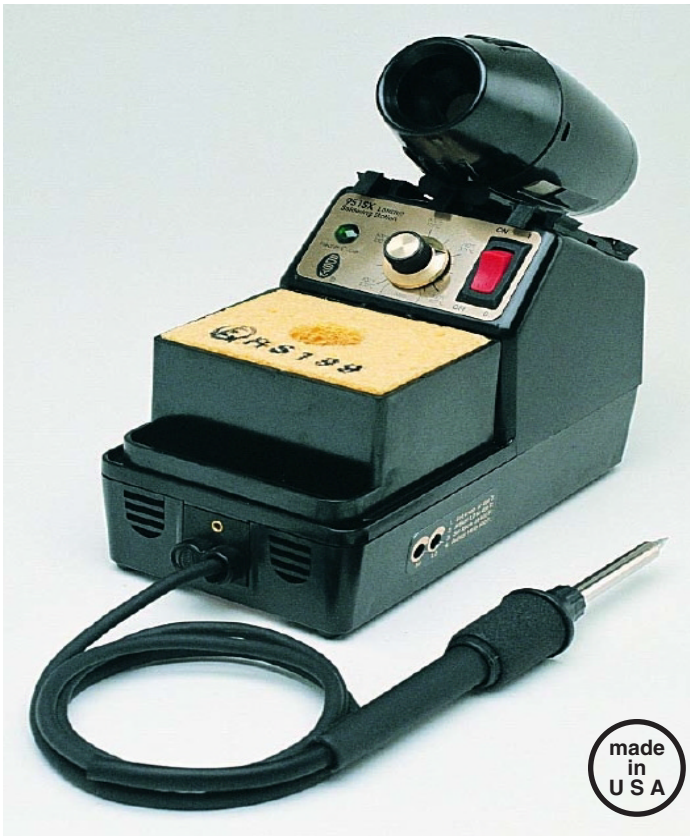

Instruction manual

Specifications for Model 951SX-230

Power Requirements	230V, 50/60 Hz
Power Rating	15W - 220W
Heater Rating	230V, 95W
Temperature Range	400°F-800°F/205°C-427°C
Temperature Regulation	±6°F/±3°C
Tip-to-Ground Voltage Leakage/Resistance	< 2mV/< 2 ohms
Overall Dimension	4.1"W x 8.2"H x 10"D 104 mm x 208 mm x 254 mm
Weight	2.5 lbs/1.1 kg

Contents

951SX-230 includes	1 - LT375 Soldering Tip
PD528	Tool Pod
SH230	Sponge Holder (Includes RS199 Cleaning Sponge, RS243 Leveling Pad, LN230 Liner)
WP556	WIGAPRY Low Static Computer Aid

DISTINGUISHING FEATURES

Power Cord

For 951SX-230

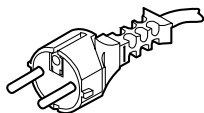

For 951SX-230B
13A Fuse inside

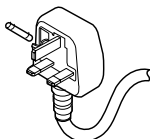

For 951SX-230I

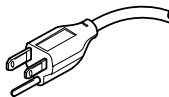

For 951SX-230P

POWER CORD WIRING

BROWN to LINE
BLUE to NEUTRAL
GRN/YEL to GROUND



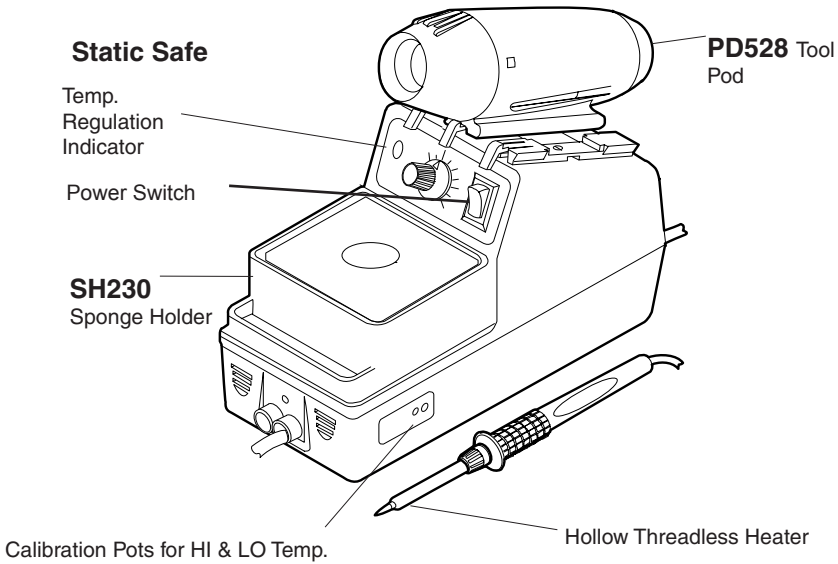

WARNING:

DO NOT HIT OR TAP THE SOLDERING TOOL. THE HEATER ELEMENT WILL BREAK!!!

MAINTENANCE

• Replace RS199 Cleaning Sponge

1. Fill water only up to the top of the **RS243** Leveling Pad.
2. Depress **RS199** to moisten it completely.

• Replace SC581 Solder Collector

1. Hold the Housing firm and turn Cap counter-clockwise and pull it away from the Housing.
2. Remove used **SC581** and replace with a new one.
3. Reassemble Pod with TOP of the Cap in proper position.

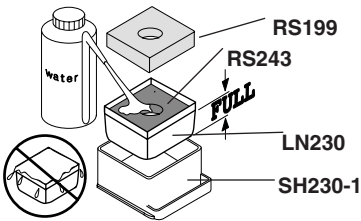

CAUTION:

Over-filling can cause thermal shock to the tip or heating element during tip cleaning.

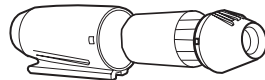

SR042
Thermal Housing

SC581
Solder Collector

SR043
Front Housing

TIP CLEANING

To maintain proper Tip to Ground resistance.

1. Remove Tip from Heater Assembly.
2. Using a **ST707 Soldering Tool Maintenance Brush**, clean Tip and Heater Barrel at surfaces shown.
3. Install the tip and tighten RS372 Retaining Sleeve. Take note of the gap to ensure proper fitting.

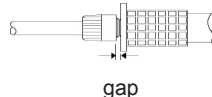
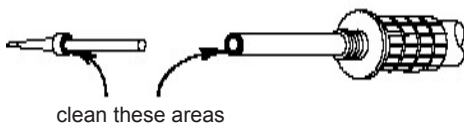

TIP CARE

1. Set desired temperature. Blinking Neon Lamp means Tool is ready.
2. TIN the Tip. (apply solder)
3. Do not rub, bend or reshape the Tip.
4. Always clean the Tip by wiping it against the saturated sponge and always RE-TIN.

TEMPERATURE CALIBRATION

1. Turn on power and set Temperature Control Knob to 400°F (205°C).
2. Using a clean and well tinned Tip, apply a small amount of solder on the Tip, just enough to form a bead on top of the Tip.
3. Place the center of the thermocouple wire of the **SDS100** on top of the bead.
4. Again, apply a small amount of solder on the center of the thermo-couple wire, just enough to embed the center.
5. Adjust LO-Temp. Calibration Pot so the Meter will read 400°F (205°C).
6. Set Temperature Control Knob to 800°F (427°C).
7. Adjust Hi-Temp. Calibration Pot so the Meter will read 800°F (427°C).

MS412

Temperature Calibration System

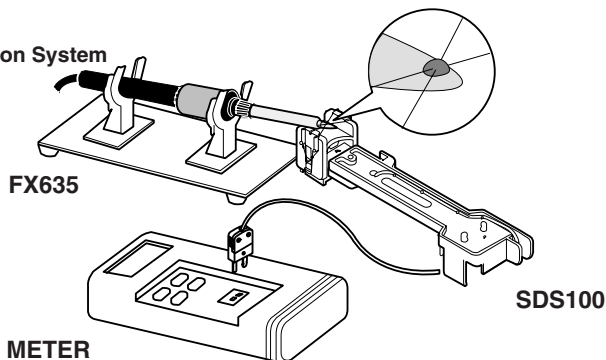

CHANGING TIP

DO NOT USE the soldering tool if soldering tip is loose. This will cause the heater element to break.

1. MAKE SURE YOUR TOOL IS COOL!
2. Turn Retaining Sleeve counter-clockwise to remove.
3. Remove old Soldering Tip.
4. Insert new Tip.
5. Install Retaining Sleeve. (should be "finger" tight only.)

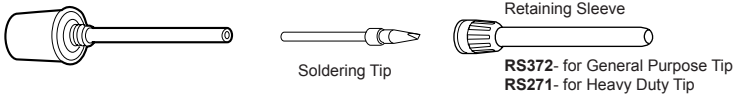

SOLDERING TIPS			
Iron Plated for long life•Nickel and Chrome Plated for optimum heat transfer CONTACT EDSYN FOR MORE SELECTIONS		A	B
	LT374 Standard Probe	.03 (0.8 mm)	.48 (12.2 mm)
	LT375 Standard Spade	.06 (1.5 mm)	.48 (12.2 mm)
	LT392 Extra-Long Needle Point	.02 (0.5 mm)	1.13 (28.8 mm)
	LT394 Extra-Long Spade	.07 (2.0 mm)	.93 (23.6 mm)
	LT446 SMD Probe	.03 (0.8 mm)	.48 (12.2 mm)
	LT337BC Heavy Duty Terminal Spade	.10 (2.5 mm)	.74 (18.8 mm)
	LT223BC Heavy Duty Fine Spade	.06 (1.5 mm)	1.21 (30.7 mm)
	LT222BC Extra long Needle Point	.04 (1.0 mm)	1.21 (30.7 mm)
	LT153BH Jumbo Spade	.20 (4.9 mm)	.93 (23.6 mm)
	LT155BH Jumbo Angle Spade	.32 (8.3 mm)	.97 (21.1 mm)

SET-UP & REQUIRED ACCESSORIES FOR HEAVY DUTY AND JUMBO TIPS	
<p>Apply AN112 or AN122* Anti-Seize Compound to Heater and area of Tip contact.</p>	

*AN122 Anti-Seize Compound comes in syringe dispenser.

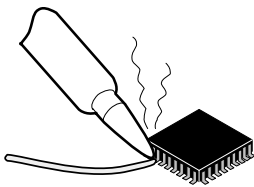

Fine point tip for SMD soldering.

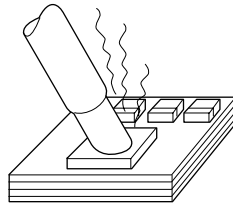

Large and heavy tip for heavy duty soldering.

951SX-230 LONER[®] SOLDERING STATION SPARE PARTS LIST

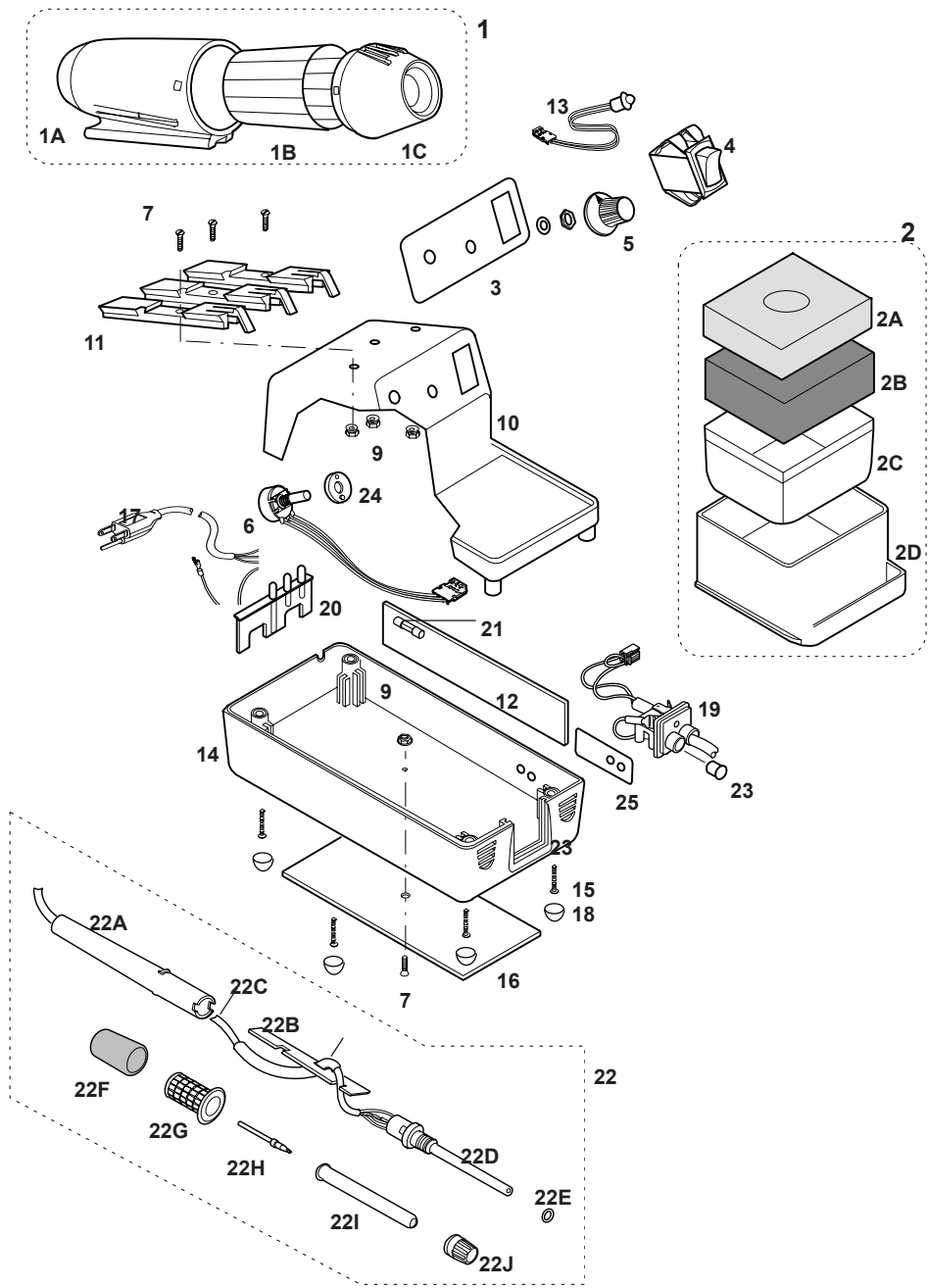

ITEM NO.	PART NO.	DESCRIPTION	QTY REQD.
1	PD528	Tool Pod	1
1A	SR042	Thermal Housing for Tool Pod	1
1B	SC581	Solder Collector for Tool Pod	1
1C	SR043	Front Housing for Tool Pod	1
2	SH230	General Purpose Sponge Holder	1
2A	RS199	Cleaning Sponge	1
2B	RS243	Leveling Pad for SH230	1
2C	LN230	Liner for SH230	1
2D	SH230-1	Sponge Holder Tray	1
3	SR302	Control Panel Label	1
4	SR452	Power Switch, DPST	1
5	SR045	Knob, Temperature Control	1
6	SR243	5K Potentiometer, Temperature Control	1
7	SR015	Flat Head Screw- Slotted #6 - 32 x 1/2	4
9	SR017	Hex Nut- #6 - 32	4
10	SR244	Top Case	1
11	SR019	Dove Tail Mount	1
12	15222W95	Circuit Board	1
13	SR573	LED Assy.	1
14	SR611	Bottom Base	1
15	SR011	Pan Head Screw- Phillip #6 - 18 x 5/8	5
16	SR054	Bottom Weight	1
17		POWER CORD ASSY. POWER CORD ONLY SR547 for 951SX-230P SR163 for 951SX-230P SR548 for 951SX-230 SR318 for 951SX-230 SR549 for 951SX-230B SR454 for 951SX-230B SR580 for 951SX-230I SR026 for 951SX-230I	1
18	SR251	Rubber Foot	4
19	SR226	Strain Relief Block for Tool Cord	1
20	SR241	Strain Relief for Power Cord	1
21	SR543	Fuse, 250V, 1 A (5mm x 20 mm)	1
22	SR336	Soldering Tool, Complete Assembly	1
22A	SR057	Handle for Tool	1
22B	SR058	Cord Strain Relief	1
22C	SR546	Tool Cord Assy., Burn Proof	1
22D	SR337	Heater Element Assembly Kit (O-Ring (22E) & Collar (22G) Included	1
22E	SR062	O-Ring	1
22F	SR063	Vinyl Sleeve	1
22G	SR064	Collar	1
22H	LT375	LONER [®] Standard Spade Tip	1
22I	RS382	Retaining Sleeve	1
22J	RB386	Retaining Bushing	1
22K	SR525	Silicone Hose, Low Static (sold per foot)	5-1/4"
23	SR053	Strain Relief for Tool Cord	1
24	SR255	Spacer for Potentiometer	1
25	SR310	Label, Calibration Pot, Right Front or Left Rear	1

951SX-230 instruction manual



ALL RIGHTS RESERVED.

NO PART OF THIS PUBLICATION INCLUDING THE INDIVIDUAL ICONS
MAY BE REPRODUCED OR UTILIZED IN ANY FORM OR BY ANY MEANS
WITHOUT THE PERMISSION OF EDSYN, INC.

THE NAMES LONER, SOLDAPULLT, SOLDAVAC, ATMOSCOPE
AUTO-VAC, IDLE-REST, PIXTER, FUMINATOR, OCTAVAC AND KLATCH
ARE REGISTERED TRADEMARKS OF EDSYN, INC.



Intellectual
Property

MOST PRODUCTS ARE COVERED BY U.S. AND
FOREIGN PATENTS AND PENDING APPLICATIONS.

DESIGN, COLOR AND MATERIALS
SUBJECT TO CHANGE WITHOUT NOTICE.

TIP STYLE ON SOLDERING, DESOLDERING AND HOT AIR TOOLS MAY VARY.

PRINTED IN U.S.A.



EDSYN INC[®]

...the power of precision

15958 Arminta Street • Van Nuys • CA 91406-1896
Web Site www.edsyn.com • eMail info@edsyn.com