

# EDSYN<sup>INC</sup>®

## 952SX-230

### LONER<sup>®</sup>

## Temperature Controlled Soldering Station

IT COMPLIES WITH MIL-S-45743E, MIL-STD-2000, DOD-STD-2000-1B,  
WS6536E AND ESD SPEC, DOD-STD-1686, DOD-HDBK-263



**instruction manual**

# Specifications for Model 952SX-230

<b>Power Requirements</b>	230V, 50/60 Hz
<b>Power Rating</b>	15W - 220W
<b>Heater Rating</b>	230V, 95W
<b>Temperature Range</b>	400°F-800°F/205°C-427°C
<b>Temperature Regulation</b>	±6°F/±3°C
<b>Tip-to-Ground Voltage Leakage/Resistance</b>	< 2mV/< 2 ohms
<b>Overall Dimension</b>	4.1"W x 8.2"H x 10"D 104 mm x 208 mm x 254 mm
<b>Weight</b>	3.1 lbs/1.4 kg

## Contents

<b>952SX</b> includes	1 - LT375 Soldering Tip 1 - LT337BC Soldering Tip
<b>PD528</b>	Tool Pod
<b>SH230</b>	Sponge Holder (Includes RS199 Cleaning Sponge, RS243 Leveling Pad, LN230 Liner)
<b>WP556</b>	WIGAPRY Low Static Computer Aid

## DISTINGUISHING FEATURES

### Power Cord

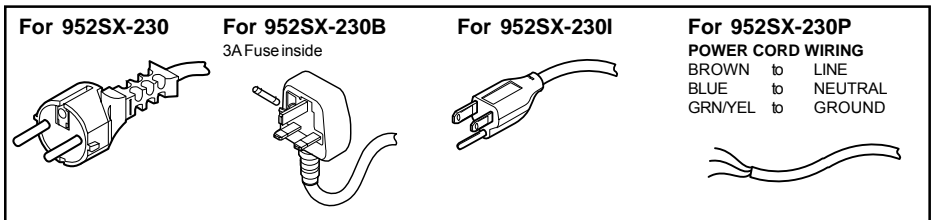

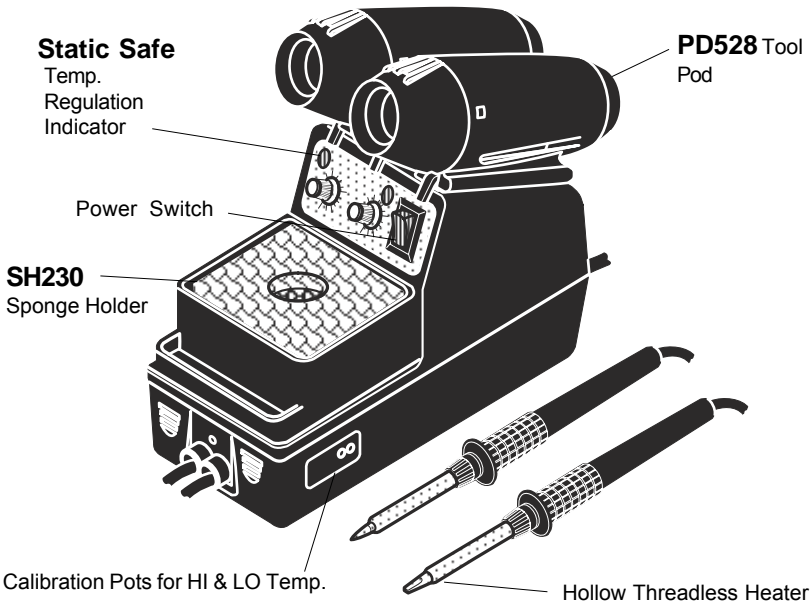

**WARNING:**

**MAINTENANCE**

**Replace RS199 Cleaning Sponge**

1. Fill water only up to the top of the RS243 Leveling Pad.

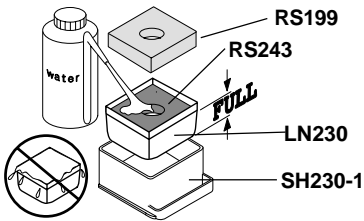

**Replace SC581 Solder Collector**

1. Hold the Housing firm and turn Cap counter-clockwise and pull it away from the Housing.
2. Remove used SC581 and replace with a new one.
3. Reassemble Pod with TOP of the Cap in

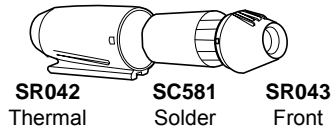

**CAUTION:**

Over-filling can cause thermal shock to the tip or heating element during tip

## TIP CLEANING

To maintain proper Tip to Ground resistance.

1. Remove Tip from Heater Assembly.
2. Using a **ST707 Soldering Tool Maintenance Brush**, clean Tip and Heater Barrel at surfaces shown.
3. Install the tip and tighten RS372 Retaining Sleeve. Take note of the gap to ensure proper fitting.  
*(If there is no gap, try replacing the RS372 Retaining Sleeve).*

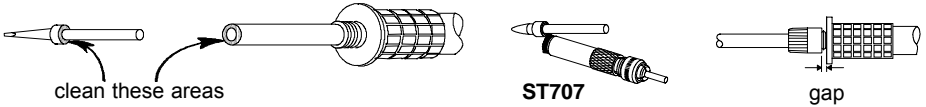

## TIP CARE

1. Set desired temperature. Blinking Neon Lamp means Tool is ready.
2. TIN the Tip. (apply solder)
3. Do not rub, bend or reshape the Tip.
4. Always clean the Tip by wiping it against the saturated sponge and always RE-TIN.

## TEMPERATURE CALIBRATION

1. Turn on power and set Temperature Control Knob to 400°F (205°C).
2. Using a clean and well tinned Tip, apply a small amount of solder on the Tip, just enough to form a bead on top of the Tip.
3. Place the center of the thermocouple wire of the **SDS100** on top of the bead.
4. Again, apply a small amount of solder on the center of the thermo-couple wire, just enough to embed the center.
5. Adjust LO-Temp. Calibration Pot so the Meter will read 400°F (205°C).
6. Set Temperature Control Knob to 800°F (427°C).
7. Adjust Hi-Temp. Calibration Pot so the Meter will read 800°F (427°C).

## MS412

Temperature Calibration System

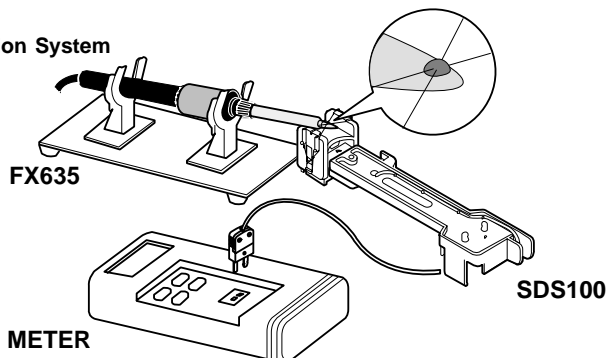

# CHANGING TIP

**DO NOT USE the soldering tool if soldering tip is loose. This will cause the heater element to break.**

1. MAKE SURE YOUR TOOL IS COOL!
2. Turn Retaining Sleeve counter-clockwise to remove.
3. Remove old Soldering Tip.
4. Insert new Tip.
5. Install Retaining Sleeve. (should be "finger" tight only.)

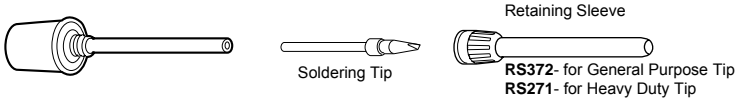

<b>SOLDERING TIPS</b>			
Iron Plated for long life/Nickel and Chrome Plated for optimum heat transfer CONTACT EDSYN FOR MORE SELECTIONS			
	<b>LT374</b> Standard Probe	.03 (0.8 mm)	.48 (12.2 mm)
	<b>LT375</b> Standard Spade	.06 (1.5 mm)	.48 (12.2 mm)
	<b>LT392</b> Extra-Long Needle Point	.02 (0.5 mm)	1.13 (28.8 mm)
	<b>LT394</b> Extra-Long Spade	.07 (2.0 mm)	.93 (23.6 mm)
	<b>LT446</b> SMD Probe	.03 (0.8 mm)	.48 (12.2 mm)
	<b>LT337BC</b> Heavy Duty Terminal Spade	.10 (2.5 mm)	.74 (18.8 mm)
	<b>LT223BC</b> Heavy Duty Fine Spade	.06 (1.5 mm)	1.21 (30.7 mm)
	<b>LT222BC</b> Extra long Needle Point	.04 (1.0 mm)	1.21 (30.7 mm)
	<b>LT153BH</b> Jumbo Spade	.20 (4.9 mm)	.93 (23.6 mm)
	<b>LT155BH</b> Jumbo Angle Spade	.32 (8.3 mm)	.97 (21.1 mm)

  

<b>SET-UP &amp; REQUIRED ACCESSORIES FOR HEAVY DUTY AND JUMBO TIPS</b>			
<p>Apply <b>AN112 or AN122* Anti-Seize Compound</b> to Heater and area of Tip contact.</p>	<p>"BC"</p>	<p>HEAVY DUTY TIP RS271</p>	
	<p>JUMBO TIP RS351</p>	<p>AC735</p>	<p>TA350</p>

\*AN122 Anti-Seize Compound comes in syringe dispenser.

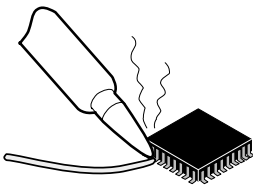

Fine point tip for SMD soldering.

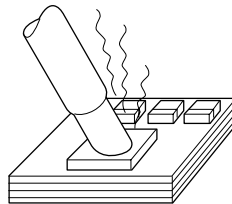

Large and heavy tip for heavy duty soldering.

# 952SX-230 LONER<sup>®</sup> SOLDERING STATION SPARE PARTS LIST

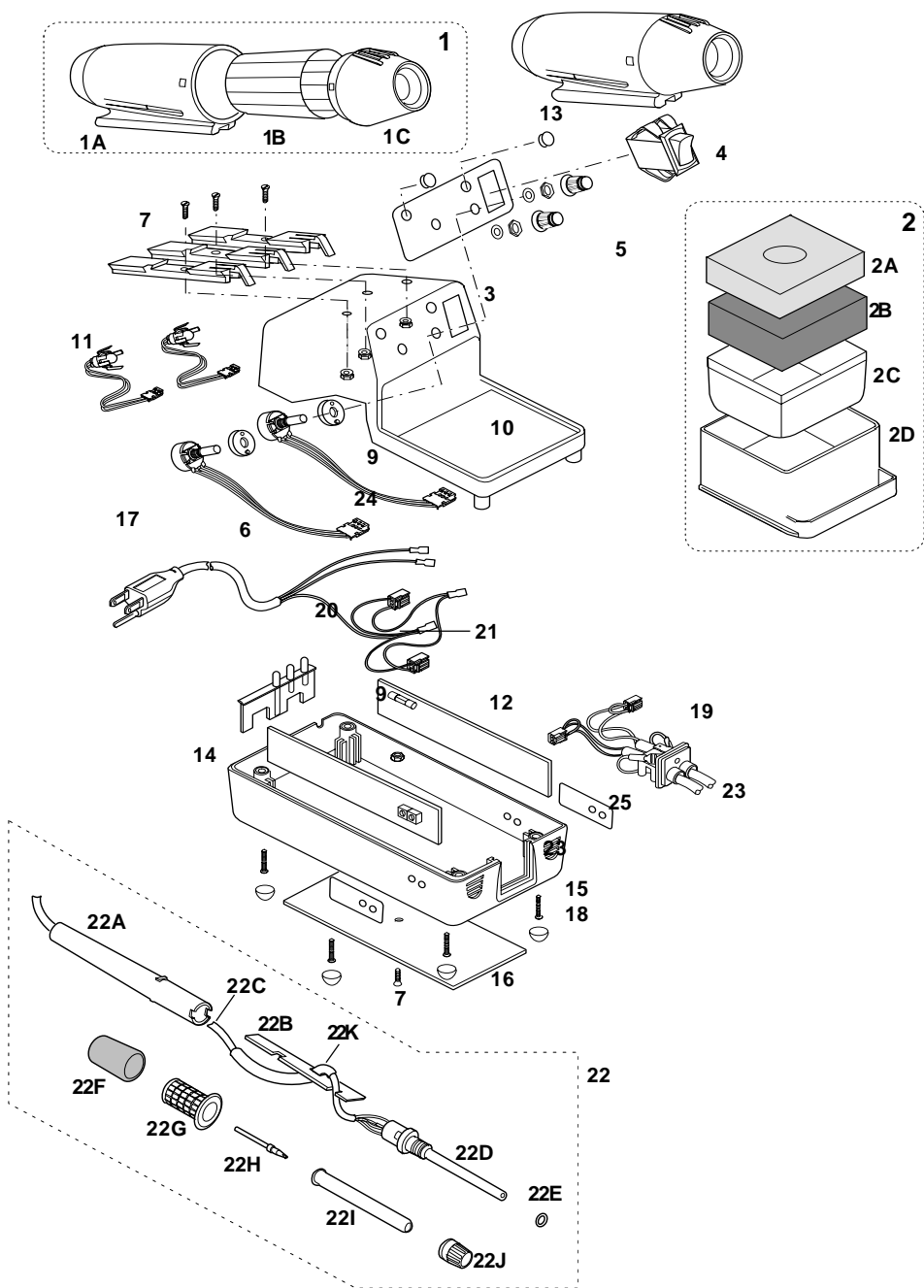

ITEM NO.	PART NO.	DESCRIPTION	QTY REQ'D
1	<b>PD528</b>	ToolPod	2
1A	<b>SR042</b>	Thermal Housing for Tool Pod	2
1B	<b>SC581</b>	Solder Collector for Tool Pod	2
1C	<b>SR043</b>	Front Housing for Tool Pod	2
2	<b>SH230</b>	General Purpose Sponge Holder	1
2A	<b>RS199</b>	Cleaning Sponge	1
2B	<b>RS243</b>	Leveling Pad for SH230	1
2C	<b>LN230</b>	Liner for SH230	1
2D	<b>SH230-1</b>	Sponge Holder Tray	1
3	<b>SR303</b>	Control Panel Label	1
4	<b>SR452</b>	Power Switch, Illuminated	1
5	<b>SR068</b>	Knob, Temperature Control	2
6	<b>SR243</b>	5K Potentiometer, Temperature Control	2
7	<b>SR015</b>	Flat Head Screw- Slotted #6 - 32 x 1/2	4
9	<b>SR467</b>	Hex Nut- #6 - 32	4
10	<b>SR781</b>	Top Case	1
11	<b>SR019</b>	Dove Tail Mount	1
12	<b>15222W95</b>	Circuit Board	2
13	<b>SR573</b>	LED Assy.	2
14	<b>SR052</b>	Bottom Base	1
15	<b>SR011</b>	Pan Head Screw- Phillip #6 - 18 x 5/8	5
16	<b>SR054</b>	Bottom Weight	1
17		Power Cord Assy.	1
18	<b>SR251</b>	Rubber Foot	4
19			
20	<b>SR241</b>	Strain Relief for Power Cord	1
21	<b>SR249</b>	Fuse, 250V, 1 A (5mm x 20 mm)	2
22	<b>SR860</b>	Soldering Tool, Complete Assembly	2
22A	<b>SR057</b>	Handle for Tool	2
22B	<b>SR058</b>	Cord Strain Relief	1
22C	<b>SR280</b>	Tool Cord Assy., Burn Proof	2
22D	<b>SR337</b>	Heater Element Assembly Kit (O-Ring (22E) & Collar (22G) Included	2
22E	<b>SR062</b>	O-Ring	2
22F	<b>SR063</b>	Vinyl Sleeve	2
22G	<b>SR064</b>	Collar	2
22H	<b>LT375</b>	LONER <sub>FC</sub> Standard Spade Tip	1
22I	<b>RS382</b>	Retaining Sleeve	1
22J	<b>RB386</b>	Retaining Bushing	1
22K	<b>SR525</b>	Silicone Hose, Low Static (sold per foot)	5-1/4"
23	<b>SR053</b>	Strain Relief for Tool Cord	1
24	<b>SR255</b>	Spacer for Potentiometer	2
25	<b>SR310</b>	Label, Calibration Pot, Right Front or Left Rear	1
26	<b>SR311</b>	Label, Calibration Pot, Left Front or Right Rear	1
27	<b>LT337BC</b>	Heavy Duty Soldering Tip	1
28	<b>RS271</b>	Retaining Sleeve, Heavy Duty	1



ALL RIGHTS RESERVED.

NO PART OF THIS PUBLICATION INCLUDING THE INDIVIDUAL ICONS  
MAY BE REPRODUCED OR UTILIZED IN ANY FORM OR BY ANY MEANS  
WITHOUT THE PERMISSION OF EDSYN, INC.

THE NAMES LONER, SOLDAPULLT, SOLDAVAC, ATMOSCOPE, AUTO-VAC, IDLE-REST,  
OCTAVAC AND KLATCH  
ARE REGISTERED TRADEMARKS OF EDSYN, INC.



Intellectual  
Property

MOST PRODUCTS ARE COVERED BY U.S. AND  
FOREIGN PATENTS AND PENDING APPLICATIONS.

DESIGN, COLOR AND MATERIALS  
SUBJECT TO CHANGE WITHOUT NOTICE.

TIP STYLE ON SOLDERING, DESOLDERING AND HOT AIR TOOLS MAY VARY.

PRINTED IN U.S.A.



15958 Arminta Street • Van Nuys • CA 91406-1896  
Web Site [www.edsyn.com](http://www.edsyn.com) • eMail [info@edsyn.com](mailto:info@edsyn.com)