

FXI9

Installation Kit for FX10 Tip Extraction Unit

CONTENTS

Item	Quantity	Description
1	7	2.5m Long 32mm Tube
2	1	2.5m Long 32mm Flexi Tube
3	14	Cobra Clips
4	14	Screws
5	12	Clear Plugs
6	4	Red End Caps
7	3	32mm T (one with sleeve)

INSTRUCTIONS

Fix 32mm tube to the most convenient position on the benches, usually at the back or underneath, using two cobra clips (item 3) and screws (item 4) per length of tube. The tube can be cut to length using a sharp knife or hacksaw. The tube can be joined together using 100mm lengths of flexible tube cut from the 2.5m length supplied. The flex pushes over the tube to make a vacuum tight connection. The remainder of the flexible tube should be used to connect the unit to the pipe work. Open ends of pipe run should be sealed by inserting a red end cap (item 6) into the tube.

At each point along the bench where a soldering iron is to be used, a 14mm hole should be drilled in the pipe and a clear plug inserted. (Care should be taken not to enlarge the hole size as the plug needs to be a tight fit.)

Typical layout shown on page 2.

Should you experience any difficulties with the installation please call our Customer Service Department.

EDSYN, Inc.

15958 Arminta Street Van Nuys CA 91406 Phone: 818.989.2324 Fax: 818.989.2324 www.edsyn.com

Typical layout

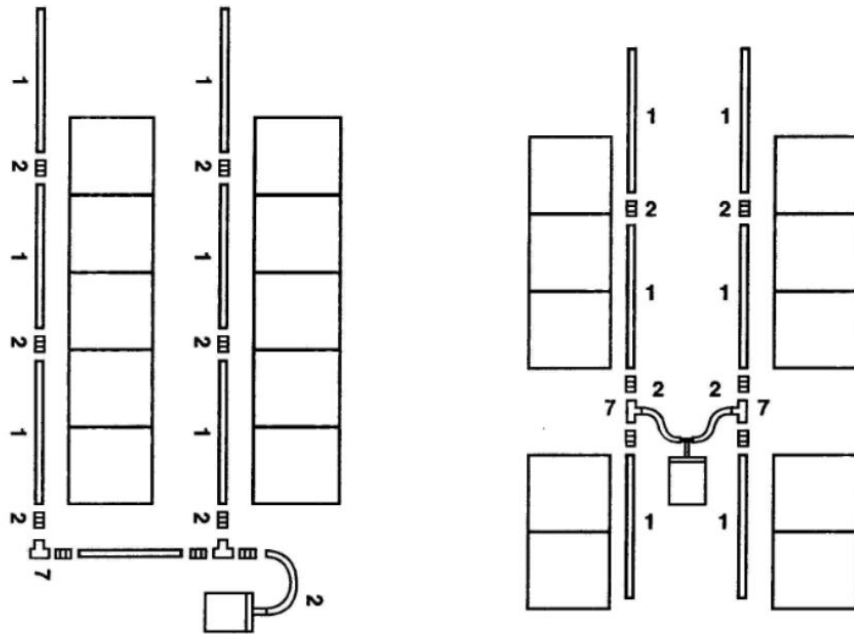
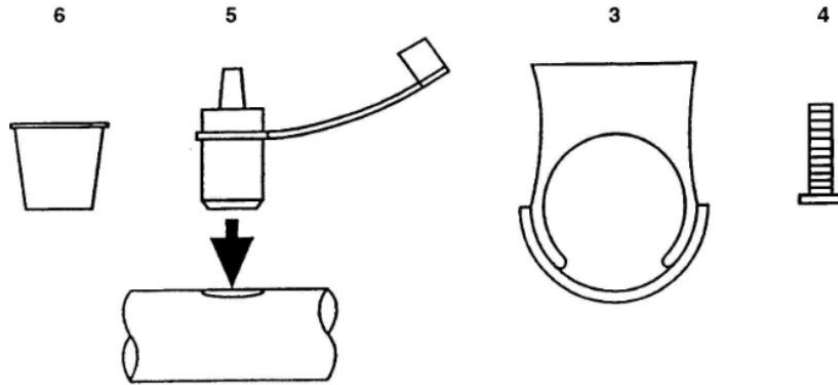

EDSYN, Inc.

15958 Arminta Street Van Nuys CA 91406 Phone: 818.989.2324 Fax: 818.989.2324 www.edsyn.com