

# EDSYN<sup>INC</sup>®

## ZD905V-230, -B, -I *SOLDAPULLT*

### HOT TIP DESOLDERING STATION

- COMPLIES WITH MIL-S-45743E, MIL-STD-2000, DOD-STD-2000-1B, WS6536E AND ESD SPEC, DOD-STD-1686, DOD-HDBK-263
- CE



Hot Tip Desoldering



Soldering

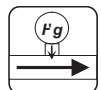

Vacuum Generator

instruction manual

(MADE IN THE  
U.S.A.)

# FEATURES



Static Safe

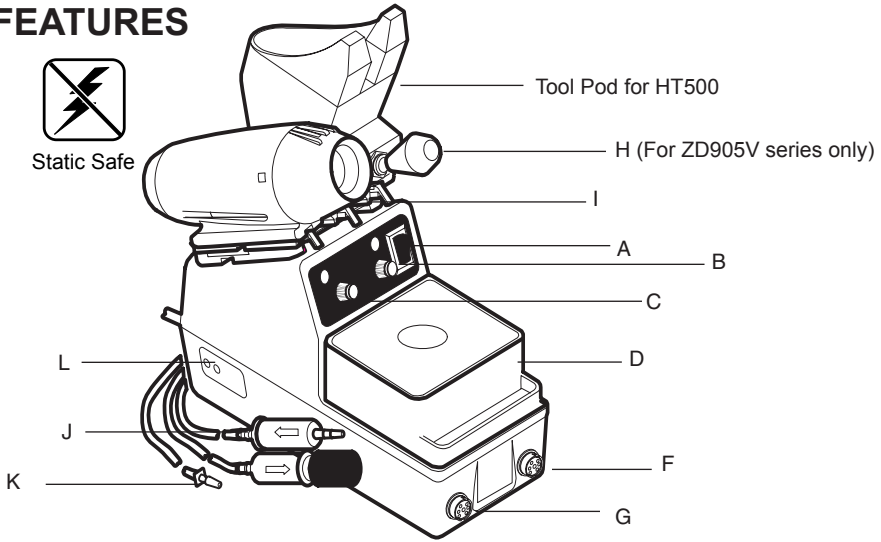

- A) Illuminated Power Switch.
- B) Temperature Control Knob, indication: 400°F - 800°F.
- C) Temperature Regulation Lamps for each Tool.
- D) SH230 includes RS199 Cleaning Sponge, LN230 Liner and RS243 Leveling Pad.
- F) 24V controlled output. Desoldering (right)
- G) 24V controlled output. Soldering (left)  
DO NOT INTERCHANGE TOOL CONNECTION.
- H) PM100 Vacuum Generator.
- I) PD528 holds Tool when not in use.
- J) AF110 Vacuum Filter (for ZD905V & ZD905V-11 only), connect to Vacuum Hose of HT500.
- K) Air Pressure input, 60 - 90 psi. (4.1 - 6.2 bar).
- L) Set Pots.

# DISTINGUISHING FEATURES

## Power Cord

For ZD905-230

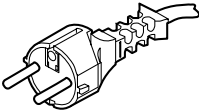

For ZD905-230B  
3A Fuse inside

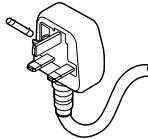

For ZD905-230I

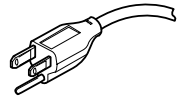

# TROUBLE SHOOTING

Symptoms	Cause	Remedy
Weak or no vacuum.	a) Vacuum source not working properly. b) Loose fittings or leak along the line.	a) refer to respective instruction manuals. b) All connections are properly installed and replace cracked hoses.
Weak or no vacuum on the HT500. Solder does not adhere to Tip.	a) Dirty or clogged filter. b) Dirty or leaky valve.	a) Replace filter. b) Clean parts and replace O-rings.
Soldering Tip to	a) Temperature too high, causing Tip to oxidize.	a) Lower the temperature to 500°F. Clean the Tip and re- tin. If problem still exists, replace Tip.
Ground resistance is high No power	Poor contact between Tip and Heater.	Do the Tip Cleaning Procedure
	Blown Fuse.	Replace fuse.

Problems other than those listed should be corrected at the factory.

Ship both Tool and Power Supply together to:

EDSYN, Inc.

Customer Service

15958 Arminta Street.

Van Nuys, CA 91406-1896

## OPTIONS

PA233 Dovetail Extension Bracket allows you to install additional Tool Pods.

1. Insert Nut into slot on both sides of existing Dovetail. Use this size Nut.
2. Screw PA233 on top on Dovetail after inserting Nut into slot.

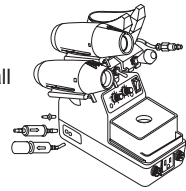
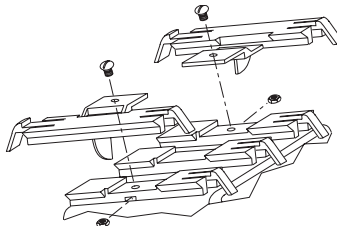

## SPECIFICATION

- 230V, 50 Hz, 38W-310W
- 24V Controlled Output
- PS902 Power Supply: 4 lbs (1.8 kg)
- PM100 Vacuum Generator: 12 oz. (341 g)
- HT500 Hot Tip Desoldering Tool: 11 oz. (312 g)
- LST11 Soldering Tool: 3 oz. (85 g)
- Temperature range: 400°F - 800°F (205°C - 425°C)
- Temperature regulation:  $\pm 6^\circ\text{F}$  ( $\pm 3^\circ\text{C}$ )
- Voltage leakage from tip to ground less than 2 MV
- Tip to ground resistance less than 2 ohm
- Complies with MIL-S-45743E, DOD-STD-2000-1B, MIL-STD-2000, WS6536E and ESD SPEC, DOD-STD-1686, DOD-HDBK-

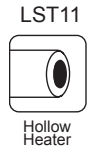

**LST11 LONER®**  
 24V, 50W Soldering Instrument  
 3 oz (85 g)

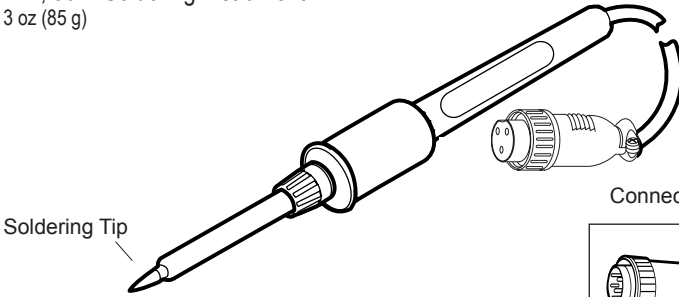

Connector

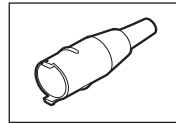
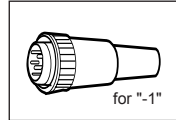

**TIP CARE**

1. Plugged-in Tool to 24V temperature controlled Power Supply & set to desired temperature.
2. TIN the Tip (apply solder) before soldering.
3. Do not rub, bend or file Tip.
4. Always clean the Tip by wiping it against the saturated sponge.
5. Always RE-TIN the Tip before and after using.

**BASIC SOLDERING**

1. Allow Tool to heat up.
2. Pre-heat the area to be soldered. Approximately 2 sec. for component leads.
3. With the Tip still in contact with the working area, apply solder on the working area.  
(for solder, ask for SS652 or SS653)
4. Always clean the Tip by wiping against the edge of the moist sponge and re-tin.

**DESOLDERING**

1. Melt solder in the area you want to desolder.
2. While keeping the solder in a molten state, use a Desoldering Tool, EDSYN® SOLDAPULLT® to extract the molten solder.

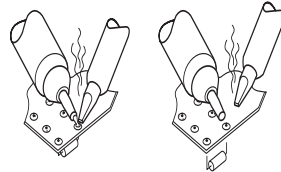

**CHANGING TIP**

**LST11**

1. MAKE SURE YOUR TOOL IS COOL!
2. Turn RS372 counter-clockwise to remove.
3. Remove old Soldering Tip.
4. Insert new Tip.
5. Install RS372.

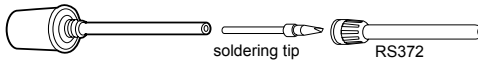

**MAINTENANCE**

**PD528 Replace SC581 Solder Collector**

1. Hold the Housing firm and turn Cap counter-clockwise and pull it away from the Housing.
2. Remove used SC581 and replace with a new one.
3. Reassemble Pod with TOP of the Cap in proper position.

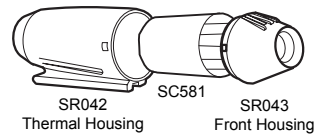

## SOLDERING TIPS

Iron Plated for long life-Nickel and Chrome  
Plated for optimum heat transfer  
CONTACT EDSYN FOR MORE SELECTIONS

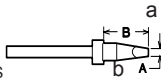

			a	b
	LT374	Standard Probe	.03 (0.8 mm)	.48 (12.2 mm)
	LT375	Standard Spade	.06 (1.5 mm)	.48 (12.2 mm)
	LT392	Extra-Long Needle Point	.02 (0.5 mm)	1.13 (28.8 mm)
	LT394	Extra-Long Spade	.07 (2.0 mm)	.93 (23.6 mm)
	LT446	SMD Probe	.03 (0.8 mm)	.48 (12.2 mm)
	LT337BC	Heavy Duty Terminal Spade	.10 (2.5 mm)	.74 (18.8 mm)
	LT223BC	Heavy Duty Fine Spade	.06 (1.5 mm)	1.21 (30.7 mm)
	LT222BC	Extra long Needle Point	.04 (1.0 mm)	1.21 (30.7 mm)
	LT153BH	Jumbo Spade	.20 (4.9 mm)	.93 (23.6 mm)
	LT155BH	Jumbo Angle Spade	.32 (8.3 mm)	.97 (21.1 mm)

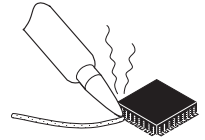

Fine point tip for SMD soldering.

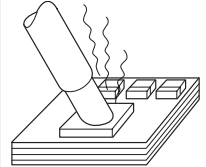

Large and heavy tip for heavy duty soldering.

### SET-UP & REQUIRED ACCESSORIES FOR HEAVY DUTY AND JUMBO

Apply AN112 or AN122\*  
Anti-Seize Compound to  
Heater and area of  
Tip contact.

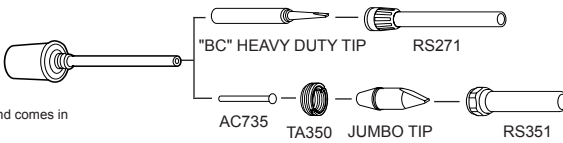

\*AN122 Anti-Seize Compound comes in  
syringe dispenser.

## TEMPERATURE CALIBRA-

AIR MOVEMENT WILL AFFECT THE TEMPERATURE  
READING. WORK IN AN AREA WHERE THIS IS

1. Turn on power and set Temperature Control Knob to 400°F.
2. Using a clean and well tinned Tip, apply a small amount of solder on the Tip, just enough to form a bead on top of the Tip.
3. Place the center of the thermocouple wire of the SDS100 on top of the bead.
4. Again, apply a small amount of solder on the center of the thermo-couple wire, just enough to embed the center.
5. Adjust LO-Temp. Calibration Pot so the Meter will read 400°F.
6. Set Temperature Control Knob to 800°F.
7. Adjust HI-Temp. Calibration Pot so the Meter will read 800°F.

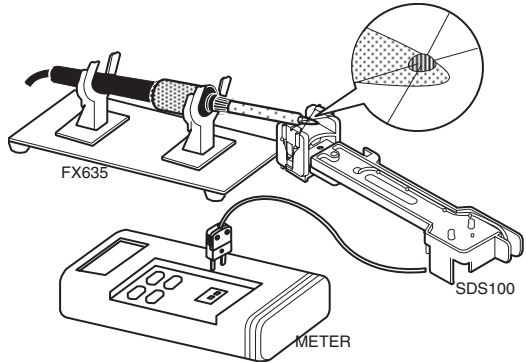

## MAINTENANCE

### Cleaning sponge

1. Keep sponge moist by adding clean water.
2. Replace dirty sponge to prevent tip contamination during tip cleaning.

### CAUTION:

Over-filling can cause thermal shock to the tip or heating element during tip cleaning.

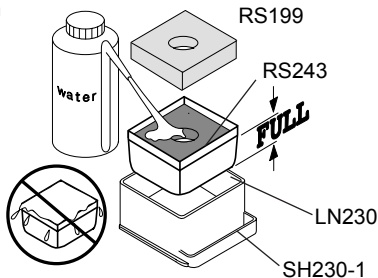

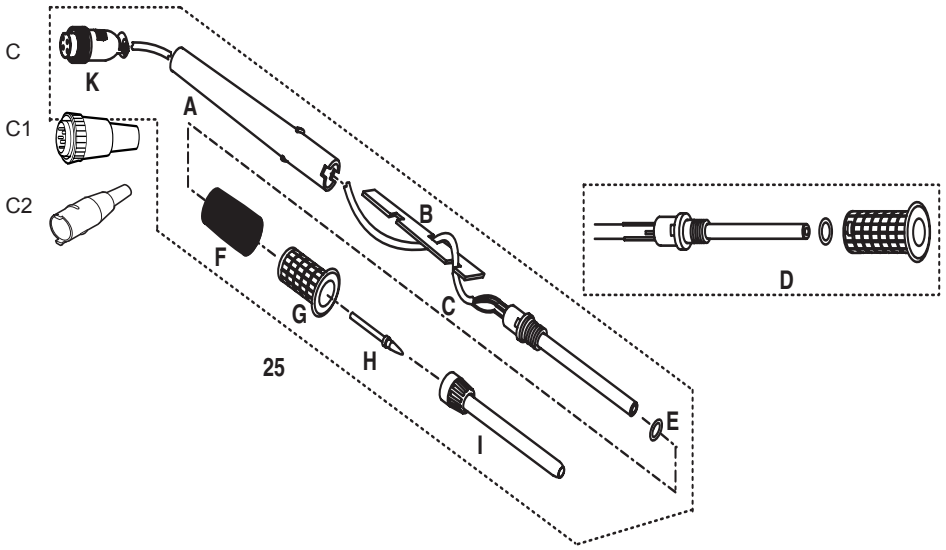

**LST11  
SPARE PARTS LIST**

ITEM NO.	PART NO.	DESCRIPTION	QTY REQ'D
A	SR057	Handle for Tool	1
B	SR058	Cord Strain Relief	1
C	SR778	Tool Cord Assy. (for LST11)	1
C1	SR250	Tool Cord Assy. (for LST11-1)	1
C2	SR777	Tool Cord Assy. (for LST11-2)	1
D	SR104	Heater Element Assembly Kit; O-Ring (e) & Collar (g) Included	1
E	SR062	O-Ring	1
F	SR063	Vinyl Sleeve	1
G	SR064	Collar	1
H	LT375	LONER <sup>®</sup> Standard Spade Tip	1
I	RS382	Retaining Sleeve	1
J	RB386	Retaining Bushing	1
K	SR525	Hose, Low Static, 1/4 I.D. (sold per foot)	5-1/4"

## HT500 *SOLDAPULLT*® Hot Tip Desoldering Tool

POWER REQUIREMENTS:

- 24V
- VACUUM SOURCE



ESD Safe

- A) Head Assembly- Includes the primary filtering system and solder debri chamber.
- B) Hot Tip Desoldering Tip- Wide range of desoldering Tips applicable.
- C) Head Shaft- Allows 4-point rotation of Head Assembly.
- D) Trigger- Activates vacuum suction.
- E) Vacuum Hose- Low Static silicone hose. Connects to vacuum source.
- F) Connector- To 24 V controlled output.



(for HT500)



(for HT500-2)



F (for HT500-1)

- G) Cleaning Shaft- For cleaning Desoldering Tip orifice: .05 (1.3 mm) and .025 (0.6 mm)

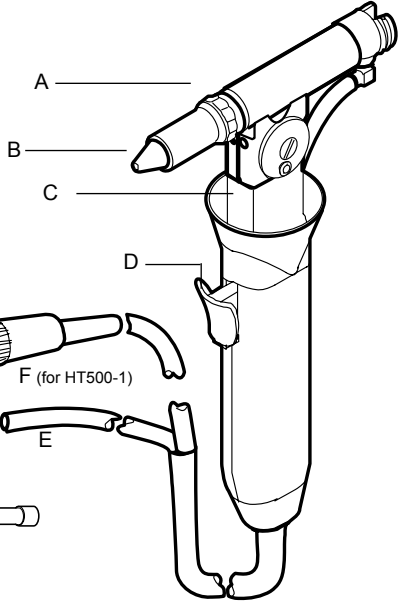

### SPECIFICATIONS

- 24V, 50/60 Hz, 70W
- Weight: 11 ozs. (312 g)
- Temperature range of 400°F to 800°F (205°C-425°C)
- Voltage leakage from tip to ground, less than 2 MV
- Tip to ground resistance, less than 2 ohms
- COMPLIES WITH MIL-S-45743E, DOD-STD-2000-1B, WS-6536E and ESD SPEC, DOD-STD-1686, DOD-HDBK-263
- UL Listed

### ADJUSTMENTS

The HT500 Head assembly can be adjusted into varying positions to suit the operator.



While Tool is in the Pod, push handle down and twist handle until it locks into 1 of it's 4 positions. Twisting counter-clockwise will permit a 180° turn. Twisting clockwise will permit a 90° turn.

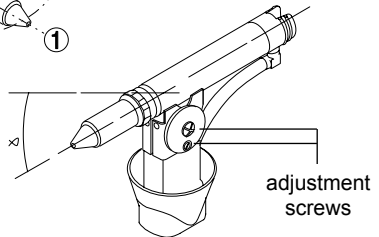
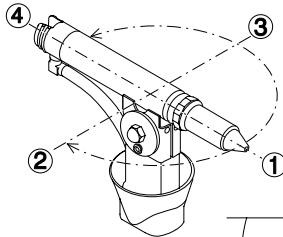

To tilt the Head assembly, loosen (2) Adjustment Screws. Tilt the Head assembly to desired position. Retighten Screws.

Note: Head Assembly does not make a full 360° turn

## OPERATION

1. Connect HT500 to 24V power supply and vacuum source.
2. Press trigger to activate vacuum.
3. Always clean the Tip with wet sponge and always re-tin (add fresh solder) during and after each operation.

NOTE: When Tip orifice is blocked, use a correct size Cleaning Shaft while pressing the Trigger to clear the obstruction.

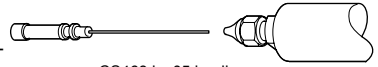

CS468 is .05 in. dia.  
CS468-1 is .025 in. dia.

## DESOLDERING POINTERS

1. When desoldering small holes on flat areas, tilt Tool to allow adequate air flow to lift solder into chamber.
2. When using SMD Tips, heat up the connections by positioning the Tool perpendicularly. When solder melts tilt the Tool and depress trigger. (SMD Tips are recommended for HT500 using external vacuum).
3. Extra-heavy duty desoldering on a multi-layered board is done by using a Heavy Duty Desoldering Tip and a Hi-Heat Soldering Tip simultaneously. Although pre-heating of the circuit board will speed up the process, it is not always necessary.

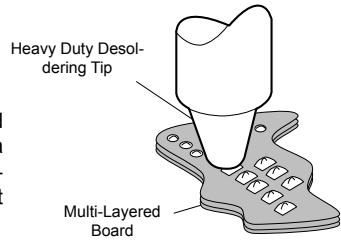
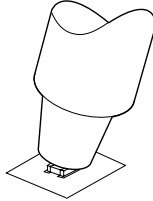
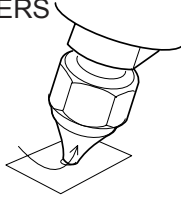

## REPLACING DESOLDERING

1. Remove RS383. Use WT619.
2. Replace Tip and install new Tip.

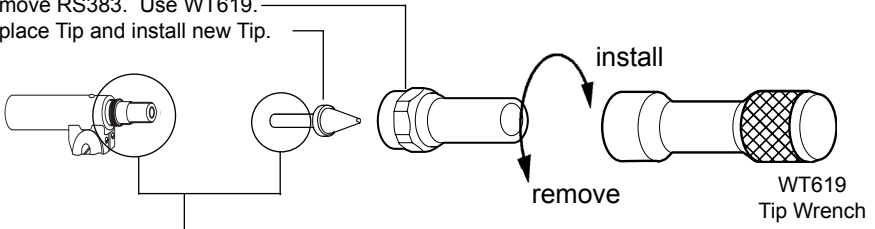

3. Apply AN112 (in tube) or AN122 (in syringe) Anti-Seize Compound before assembling.  
INSPECT DAILY
4. Install RS383.



# Hot Tip Desoldering Tips

Fractional dimensions are approx.

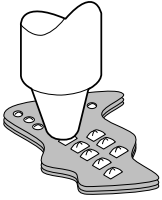

Extra-heavy duty desoldering on a multi-layered board is done by using a Medium Life Desoldering Tip.

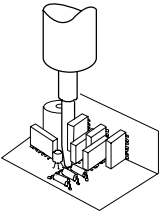

To reach deep, dense and compact areas, use a Long Funnel tip

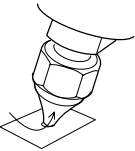

When using a Replacement Desoldering Tip to desolder small holes on flat areas, tilt Tool to allow adequate air flow to lift solder into chamber.

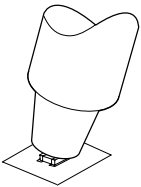

When using SMD Tips, heat up the connections by positioning the Tool perpendicularly. When solder melts, tilt the Tool and depress trigger.

DESCRIPTION	PART NO.	HOLE DIAMETER			B		
		in.	in.	mm	in.	in.	mm
<b>Medium Life</b> (High Heat Transfer)	ZD12	.03	1/32	0.8	.50	1/2	12.7
	ZD13	.04	3/64	1.0			
	ZD14	.06	1/16	1.5			
	ZD18	.07	5/16	1.8			
	ZD19	.12	1/8	3.2			
<b>Long Life</b> (Low Heat Transfer)	ZD08	.03	1/32	0.8	.44	7/16	11.8
	ZD10	.04	3/64	1.0			
	ZD11	.06	1/16	1.5			
<b>Funnel</b>	ZD107	.02	1/64	0.5	.48	31/64	12.2
	ZD112	.03	1/32	0.8			
	ZD113	.04	3/64	1.0			
<b>Long Funnel</b>	ZD111	.03	1/32	.08	1.22	17/32	31
<b>Replacement*</b>	ZD25	.03	1/32	0.8	.39	32/64	9.9
	ZD26	.04	3/64	1.0			
	ZD27	.07	5/16	1.7			
<b>SMD**</b> (FOR ZD505/905 series)	ZD57	.10	7/64	2.5	.55	9/16	13.9
	ZD58	.13	1/8	3.2			
	ZD60	.15	5/32	3.8			
	ZD61	.25	1/4	4.5			

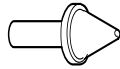

HOLE DIA.

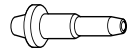
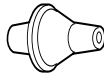
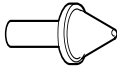

HOLE DIA.



HOLE DIA.

# Hot Tip Desoldering Tip

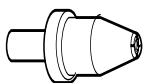

Surface Sweep Tips removes excess solder on pads for flatter surface, prior to SMD remounting.

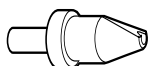

Side Sweep Tips allows removal of solder from the component side of the board.

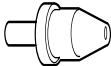
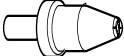
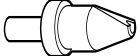
DESCRIPTION	PART NO.	HOLE DIAMETER			B		
		in.	in.	mm	in.	in.	mm
Economy** 	ZD28	.03	1/32	.08	.30	5/16	7.6
	ZD29	.04	3/64	1.0			
	ZD30	.06	1/16	1.5			
Surface Sweep** 	ZD70	W			.30	5/16	7.6
		in.	in.	mm			
Side Sweep** 	ZD71	.08	3/32	2.0	.30	5/16	7.6
		Hole Dia. = .06 in.					
Hole Dia. = .06 in.							

\*Tin New Iron Tips at Low Temperature before using.

\*\*Non-Plated Alloy

## Hot Tip set-up

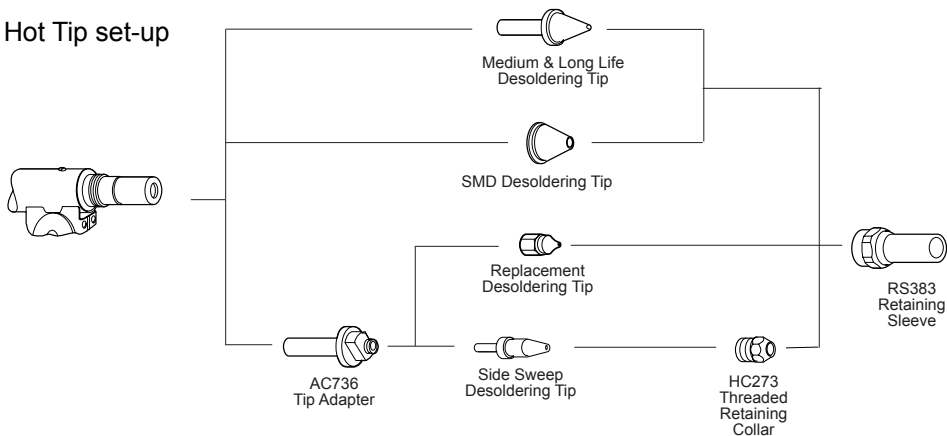

## Heater Set-up

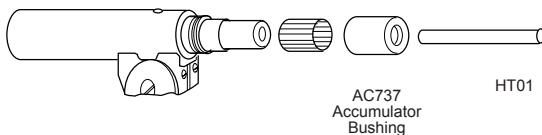

## DAILY MAINTENANCE

- Remove and inspect Tip and Heater Assy.
- Inspect all Filters
- Remove solder debri from Desoldering Head Housing

## WEEKLY MAINTENANCE

- Inspect Valve Assy.
- Inspect all O-Rings and Seals

### TO REPLACE FILTER & O-RING INSIDE DESOLDERING HEAD ASSY.

1. Pull out FC639 from Housing.
2. Unscrew SC525 from FC639 to remove AF625.
3. Insert new AF625 inside SC525 and screw back on.
4. Clean and apply OL111 on OS731 & OS132 O-Ring.

- Ⓒ - Clean  
Ⓓ - Replace

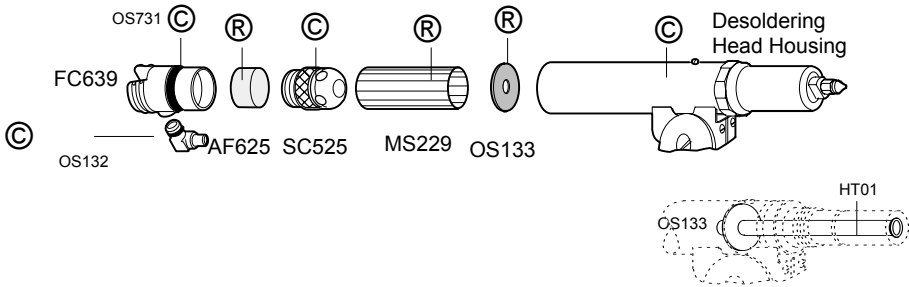

### TO REPLACE O- RINGS INSIDE VALVE ASSEMBLY

- a) Unscrew Lock Nut at the end of the HT500 Handle.
- b) Remove Handle Cover.
- c) Slide out Valve Assembly while placing your finger over the Spring Seat. **BE CAREFUL NOT TO LET THE SPRING AND THE SPRING SEAT SHOOT OUT FROM THE HOUSING**
- d) Clean all parts with alcohol only.
- e) Replace OS730 O-Ring Set (set of 3).

When installing OS133, the HT01 should go thru the OS133.

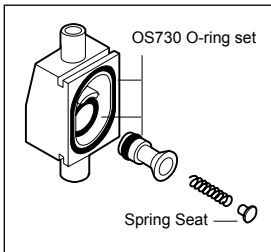
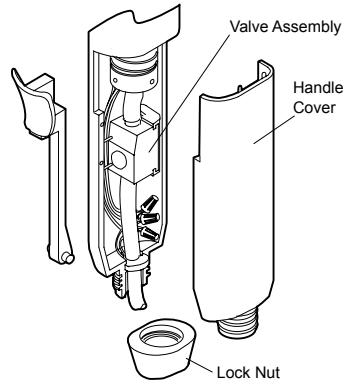

**CAUTION:** Make sure the wires are not pinched by Valve Assembly.

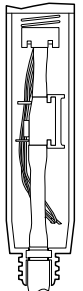

HT500/-1 **SOLDAPULLT** HOT TIP  
 DESOLDERING TOOL  
 SPARE PARTS LIST

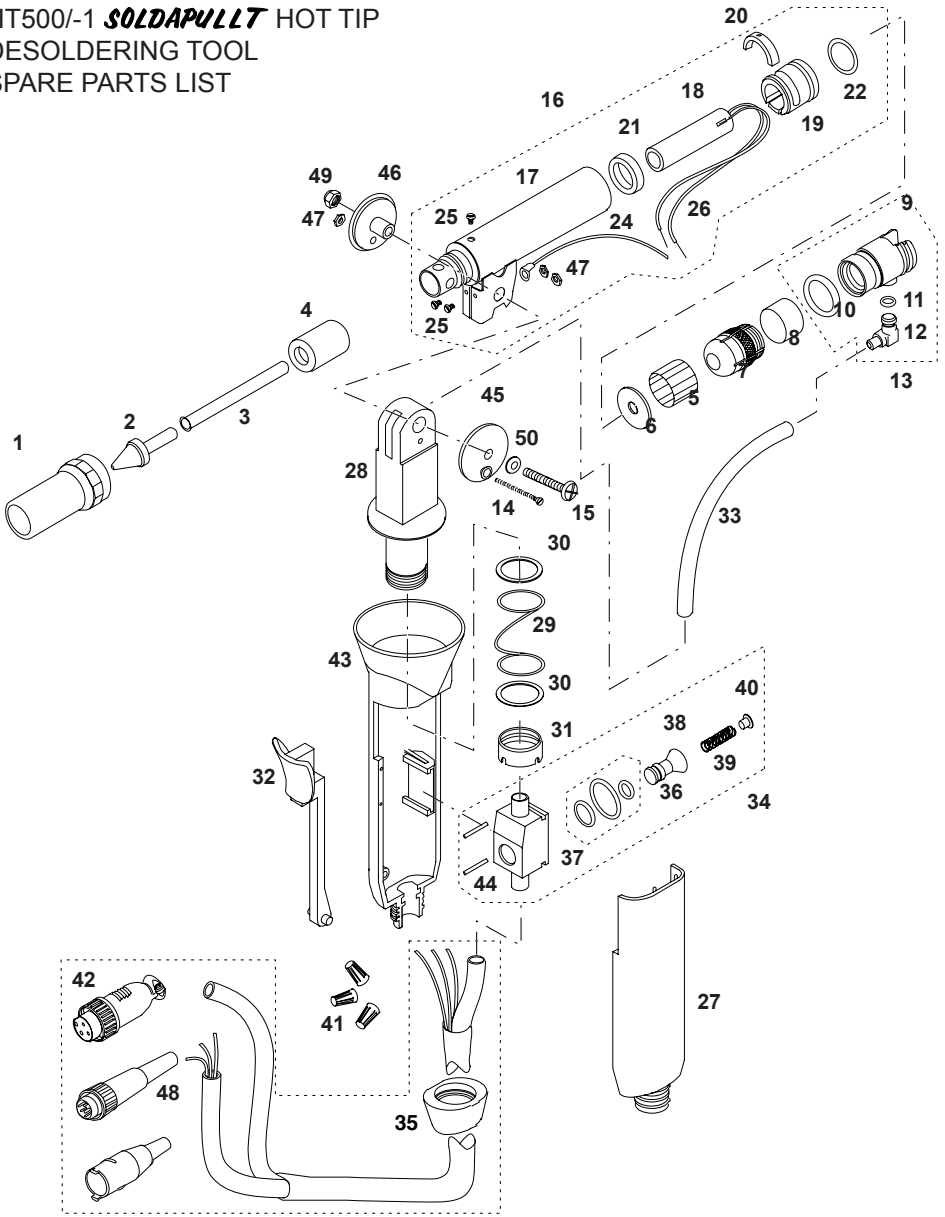

ITEM NO.	PART NO.	DESCRIPTION	QTY REQD
1	RS383	Retaining Sleeve	1
2	ZD13	Hot Tip Desoldering Tip	1
3	HT01	Hot Tube	1
4	AC737	Accumulator Bushing	1
5	MS229	Mica Sheet	1
6	OS133	Silicone Washer	1
7	SC525	Solder Cone	1

ITEM NO.	PART NO.	DESCRIPTION	QTY REQ'D
8	AF625	Felt Filter	1
9	SR148	Housing for End Cap	1
10	OS731	O-Ring for End Cap	1
11	OS132	O-Ring for End Cap Elbow Connector	1
12	SR147	Connector for End Cap	1
13	FC639	End Cap	1
14	SR008	Flat Head Slotted Screw for Index Flange	1
15	SR168	Pan Head Phillip Screw for adjusting Desoldering Head Assy.	1
16	HT500H	Desoldering Head Assembly- Repairable by EDSYN Customer Service Dept.	1
17	SR136	Desoldering Head Housing	1
18	SR120	Heater Element	1
19	SR117	Heater Element Bushing (O-Ring included)	1
20	SR118	Retaining Key for Heater Element Bushing	1
21	SR119	Teflon Spacer for Heater Element	1
22	OS731	O-Ring for Heater Bushing	1
24	SR121	Grounding Wire	1
25	SR122	Screw, 2-56 x 1/8 Pan Head Slotted	3
26	SR145	Sleeving, Braided Fiberglass	2
27	SR004	Handle Cover	1
28	SR124	Head Shaft	1
29	SR125	Spring for Head Shaft	1
30	SR126	Washer, Nylon	2
31	SR127	Retaining Nut for Head Shaft	1
32	SR128	Trigger	1
33	HL603	Hose, Low Static Silicone, 3/16" I.D.	5"
34	SR335	Valve Assy.	1
35	SR393	Nut, Retaining, for Handle	1
36	OS730	O-Ring Set (Three O-Rings)	1 set
37	SR129	Valve Housing	1
38	SR130	Poppet (O-Ring Included)	1
39	SR131	Return Spring for Poppet	1
40	SR132	Seat for Return Spring	1
41	SR133	Wire Nuts	3
42		SR134 Hose and Wiring Assembly for HT500	1
		SR565 for HT500-1 SR635 for HT500-2	
43	SR123	Handle Base	1
44	SR143	Wire Guide, Nylon, 3/8" Length	2
45	SR005	Index Flange (Screw Side)	1
46	SR006	Index Flange (Nut Side)	1
47	SR007	Nut, Hex, 2-56 thread	3
48		SR135 Connector for HT500	1
		SR353 for HT500-1 SR633 for HT500-2	
49	SR170	Cap Nut, Hex #8-32 x 5/16"	1
50	SR169	Washer, Flat, 1/16" thick	1

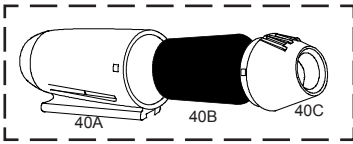

ZD905V-230 **SOLDAPULLT**<sup>®</sup>  
SPARE PARTS LIST

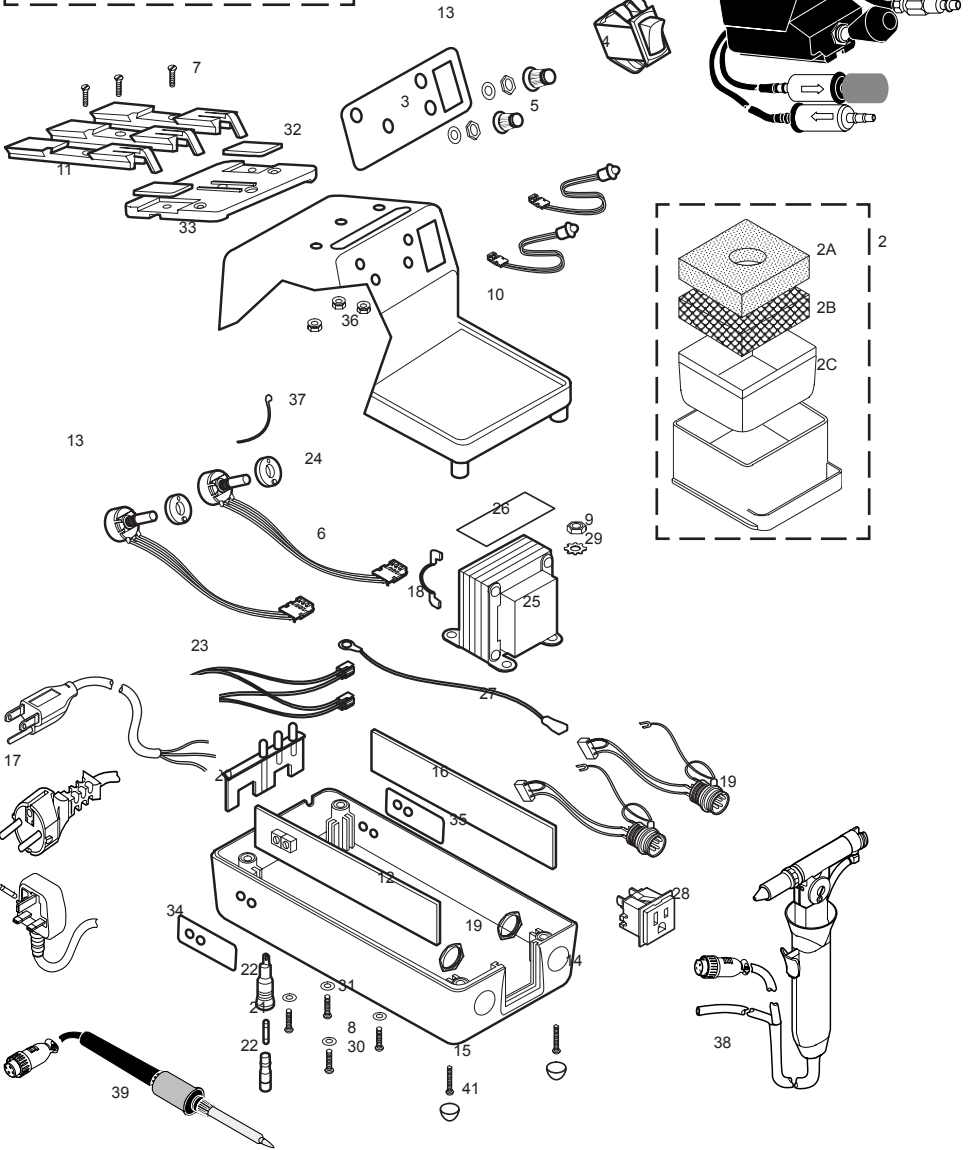

ITEM NO.	PART NO.	DESCRIPTION	QTY REQ'D
1	PM100	ATMOSCOPE Vacuum Generator (see FORM.604)	1
2	SH230	General Purpose Sponge Holder	1
2A	RS199	Replacement Sponge	1
2B	RS243	Leveling Pad for SH230	1

ITEM NO.	PART NO.	DESCRIPTION	QTY REQ'D
2C	LN230	Liner for SH230	1
2D	SH230-1	Sponge Tray Holder	1
3	SR380	Control Panel Label	1
4	SRxxx	Power Switch, 230V	1
5	SR045	Knob, Temperature Control	2
6	SR243	Temperature Control for 5K Potentiometer Assembly	2
7	SR015	Slotted Flat Head Screw, #6 - 32 x 1/2	3
8	SR016	Flat Washer, #6	4
9	SR017	Hex Nut- #6 - 32	5
10	SR735	Top Cover	1
11	SR019	Dove Tail Mount	1
12	15242W53	Circuit Board, 24V (for Soldering Tool)	1
13	SR246	LED Assy. (Green Lens included)	2
14	SR749	Bottom Base	1
15	SR011	Phillips Pan Head Screw, #6 - 18 x 5/8	4
16	15242W70	Circuit Board, 24V (for Desoldering Tool)	1
17	SR664	Power Cord Assy.	1
18	SR558	Wire Assembly, Transformer Jumper	4
19	SR727	Connector Assy. 5-Pin, 3-Wire	2
20	SR241	Strain Relief for Power Cord	1
21	SR724	Fuse, 6.3A, 250V, 5 x 20 mm	1
22	SR569	Fuse Holder	1
23	SR780	Wire Assembly, Blk & Wht, Two Circuit Connector	2
24	SR255	Spacer for Potentiometer Assy.	2
25	SR387	Transformer, 24V, 80VA, Dual Primary	1
26	SR434	Insulator for Transformer	1
27	SR748	Wire Assembly for Ground	1
28	SR	230V AC 230 Receptacle	
	SR	230V AC 230B Receptacle	
	SR037	230V AC 230I Receptacle	1
29	SR139	Star Washer, Lock, #6	6
30	SR144	Slotted Rnd. Head Screw, #6-32 x 1/2	3
31	SR561	Phillips Rnd. Head Screw, #6-32 x 3/4 (for ground)	1
32	SR562	Dovetail Riser Plate	1
33	SR036	Shelf Plate for Dovetail Riser	2
34	SR310	Label, External Calibration, Right Front or Left Rear	1
35	SR311	Label, External Calibration, Left Front or Right Rear	1
36	SR467	Hex Nut for Dovetail	3
37	SR050	Cable Tie <span style="float: right;">as req'd</span>	
38	HT500	SOLDAPULLT Hot Tip Desoldering Tool, 24V	1
39	LST11	LONER Soldering Tool, 24V	1
40	PD528	Tool Pod	1
40A	SR042	Thermal Housing for Tool Pod	1
40B	SC581	Solder Collector for Tool Pod	1
40C	SR043	Front Housing for Tool Pod	1
41	SR251	Rubber Foot	4

# ZD905V-230 instruction manual

## CALIBRATION

AIR MOVEMENT WILL AFFECT THE TEMPERATURE READING.  
WORK IN AN AREA WHERE THIS IS MINIMAL.

1. Using a clean Tip, turn on power and set Temperature Control Knob to approx. 500°F (260°C). Allow Tip to warm up.
2. Tin the tip properly and place center of the thermo-couple wire on tip.
3. Apply a small amount of solder on the center of the thermo-couple wire, to form a good contact between the tip and the thermo-couple wire.
4. Set Temperature Control Knob to 400°F (205°C).
5. Adjust LO-Temp. Calibration Pot so the Meter will read 400°F (205°C).
6. Set Temperature Control Knob to 800°F (427°C).
7. Adjust HI-Temp. Calibration Pot so the Meter will read 800°F (427°C).

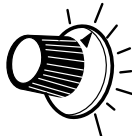

Temperature  
Control Knob

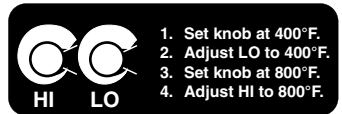

Calibration Pot

1. Set knob at 400°F.
2. Adjust LO to 400°F.
3. Set knob at 800°F.
4. Adjust HI to 800°F.

THE NAMES LONER, SOLDAPULLT, ATMOSCOPE, AUTO-VAC, IDLE-REST,  
OCTAVAC AND KLATCH  
ARE REGISTERED TRADEMARKS OF EDSYN, INC.



Intellectual  
Property

MOST PRODUCTS ARE COVERED BY U.S. AND  
FOREIGN PATENTS AND PENDING APPLICATIONS.

DESIGN, COLOR AND MATERIALS  
SUBJECT TO CHANGE WITHOUT NOTICE.

TIP STYLE ON SOLDERING, DESOLDERING AND HOT AIR TOOLS MAY VARY.

PRINTED IN U.S.A.



...the power of precision

15958 ARMINTA ST. VAN NUYS, CA 91406-1896  
PHONE: (818) 989-2324 FAX (sales): 818-997-0895  
Email: info@edsyn.com Internet: www.edsyn.com